

Isolation Thermal Break Face Fix Veneer Tie

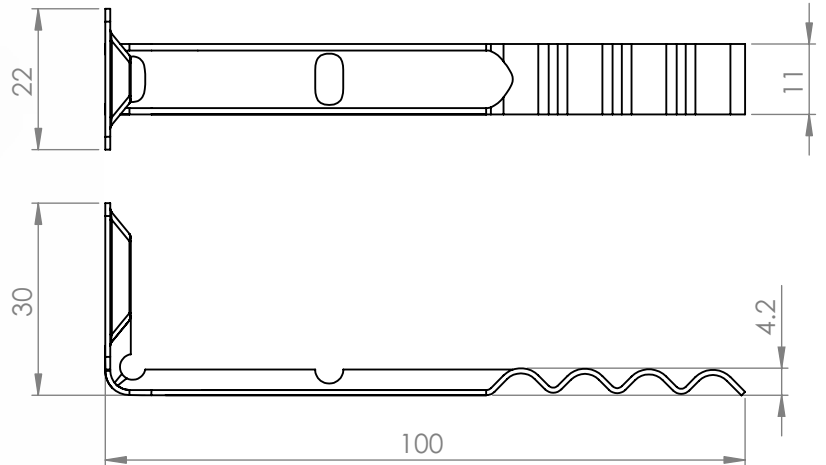

DESCRIPTION

Isolation and thermal break washer face fix veneer tie for timber or steel stud construction Type A / 50mm cavity

FEATURES

- Isolated tie so you can benefit from using a Stainless tie with a Galvanised screw and frame
- Thermally broken to create an insulated barrier
- Quicker to deploy with included driver
- Screw fastener for a faster installation time, less frame loosening
- Greater fastener tensile load
- Clay brick
- Maximum cavity 50mm
- Universal applications
- Australian design & tested AS/NZS 2699.2:2020

FIXING REQUIREMENTS

- Cerra Multipurpose Screw hex head 10g X 35mm (Metal / Timber)
- For more information contact us with your project requirements.

CORROSION CHARACTERISTICS

Stainless steel 316L (R4)
 Conforms to corrosion resistance set by AS/NZS 2699.2:2020 / AS 3700.

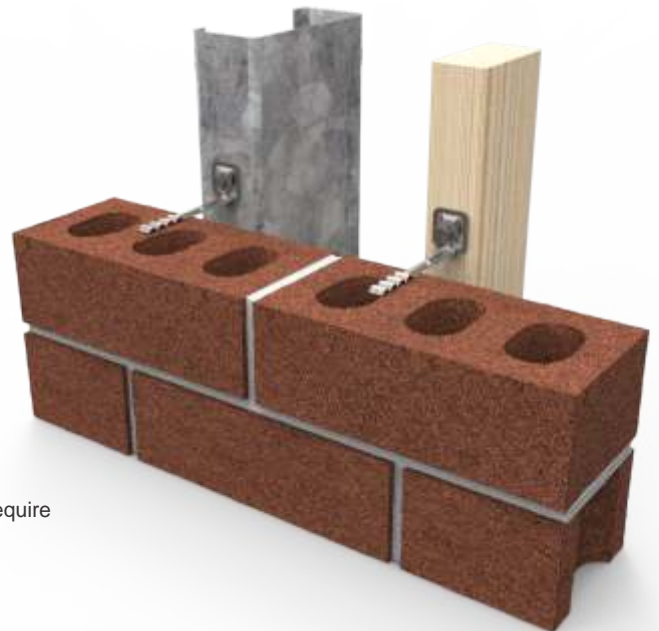

ORDERING INFORMATION

When ordering please supply use with the part number and quantity you require

CGT12-ECO-ITB

PRODUCT CODE